



CW2015CTCC

Fuel Gauge IC with Low-SOC Alert

Features

- System-Side or Pack-Side Fuel Gauging
- $\pm 3\%$ Maximum Total SOC Measurement Error
- 3C Charging Rate Supported
- 14-bit Sigma-Delta ADC for Temperature and Cell Voltage Measurement
- No Offset Accumulation During Life Time
- No Full-to-Empty Battery Learning Cycles
- No Sense Resistor Required
- SOC and RRT Available
- External Alarm/Interrupt for Low-Battery Warning Available
- Patented "FastCal" Fuel Gauging Algorithm
- Calibration After Quick Soft-Reset
- Ultra-low Power Consumption
 - Active Mode $15\mu\text{A}$
 - Sleep Mode $0.5\mu\text{A}$
- General I²C Interface
- Tiny, Lead(Pb)-Free, CSP9 Package

Applications

- Smartphone and Tablet
- Smart Watch
- BT Headphone
- TWS BT Earbuds

General Description

The CW2015 is an ultra-compact, low power consumption, system-side or pack-side, sensing resistor free, fuel gauging system IC for Lithium-ion(Li+) based batteries in handheld and portable devices.

CW2015 tracks Li+ battery's operating condition and uses state-of-the-art algorithm to report the relative State-of-Charge (SOC) of very different battery chemistry systems (LiCoOx, polymer Li-ion, LiMnOx etc.).

CW2015 includes a 14-bit Sigma-Delta ADC, a precision voltage reference and build-in accurate temperature sensor. The IC allows the end-user to eliminate the expensive sensing resistor which occupies large board area. And the IC also sends out the alarm signal if the battery SOC level reaches pre-programmed threshold.

Quick start function offers the possibility to make an initial estimation of the battery's SOC, which also enables the IC to be located on system side or pack side, giving the flexibility to system maker on pack selection.

CW2015 uses a 2-wire I²C compatible serial interface that operates in standard mode(100kHz) or fast mode(400kHz).

Typical Application

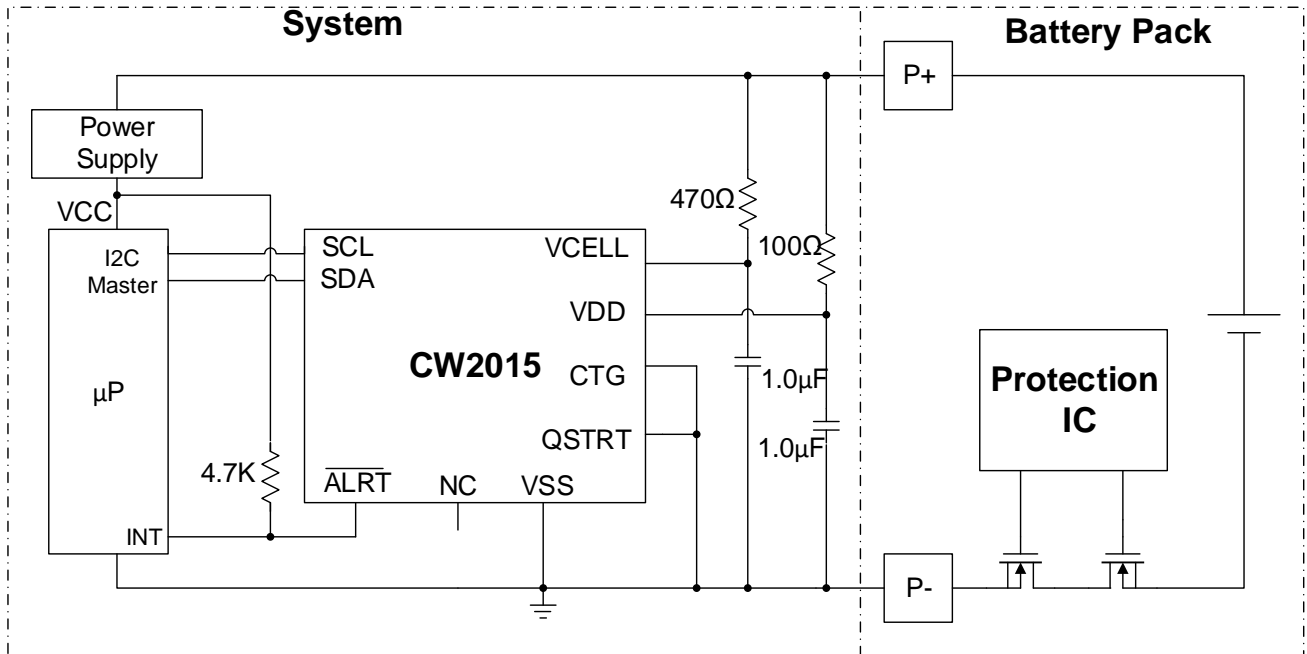

Figure 1. Typical Application Diagram (System Side)

Figure1 is a typical application diagram of CW2015 used in system side, recommended value of the external components is marked on the figure.

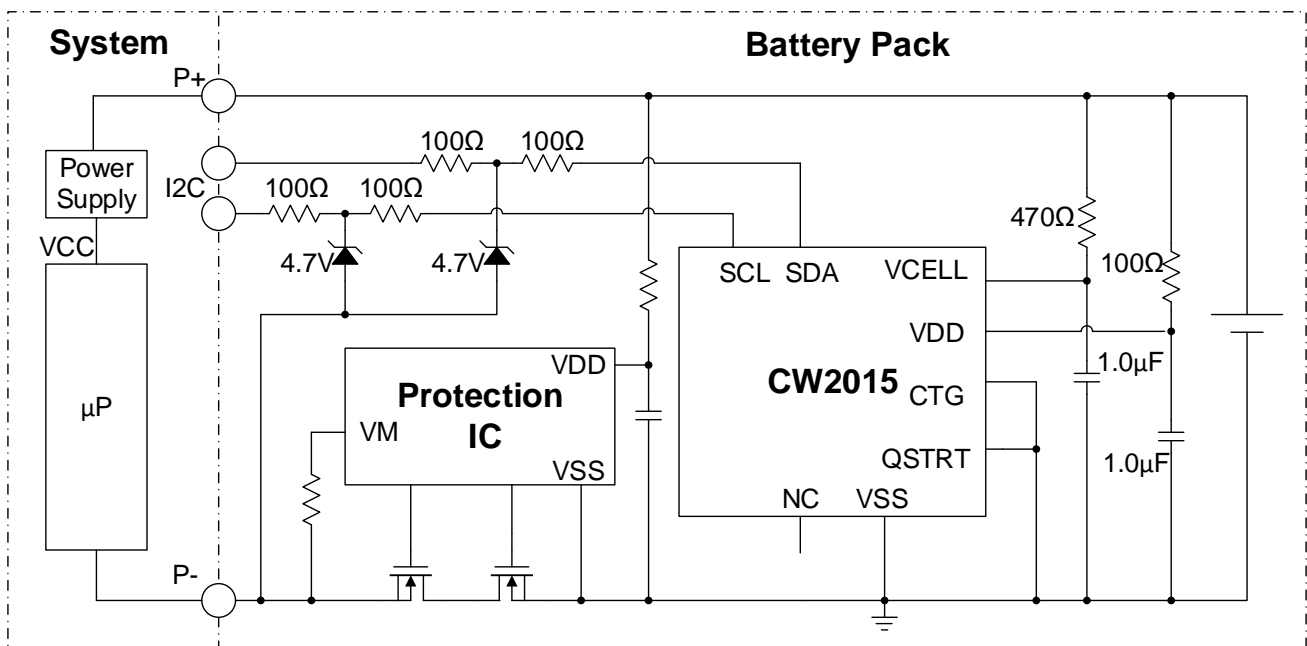

Figure 2. Typical Application Diagram (Pack Side)

Figure 2 is a typical application diagram of CW2015 used in pack side, recommended value of the external components is marked on the figure.

CW2015 can be used in 2 or more batteries connected in series, or several cells connected in parallel.

More detailed application information please refers to the application notes or contacts

support@cellwise-semi.com for more support.